



PERFORMANCE EXHAUST SYSTEM



INSTALLATION INSTRUCTIONS

67-3082

CHEVROLET / GMC
2015-2020 Tahoe / Yukon
V8-5.3L

PARTS LIST:

Description	Qty.	Part #
A TAILPIPE ASSY	1	344139
B CLAMP; 3"	1	RH-A30BF
C MIDPIPE ASSY	1	344138

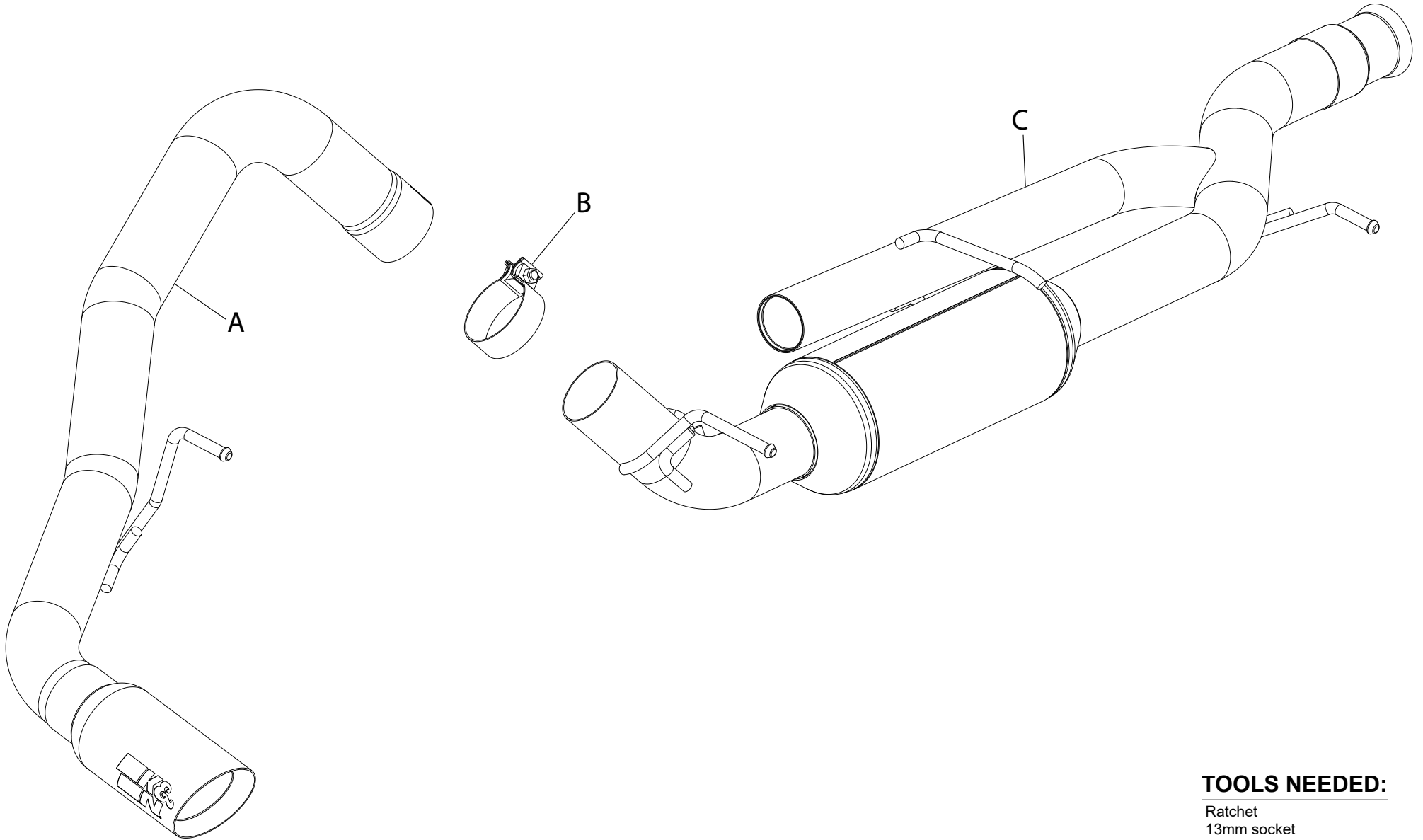

TOOLS NEEDED:

Ratchet
13mm socket
15mm socket

TO START:

1. Turn off the ignition and allow engine and exhaust to cool to the touch.

WARNING: Exhaust components can be extremely hot after vehicle operation and can severely burn you.

Raise the vehicle to access the factory exhaust system with a lift or appropriate jack and properly positioned stands. It may be helpful to spray all existing hardware and hanger assemblies being removed with a penetrating oil or similar lubricant and allow to soak, especially if older and rusted.

WARNING: If working without a lift always use the correct jack points and lifting procedures specified by the vehicle manufacturer. Serious injury or death could occur if proper safety measures are not followed.

2. Cutting the stock exhaust will be mandatory to remove, unless a vehicle lift is available and partial rear suspension disassembly is performed.



3. Cut rear tailpipe 2" from rear hanger just above the axle.



4. Remove rear tail pipe section by sliding tail pipe off rear hanger (leave rubber hanger on vehicle).



5. Once rear tail pipe has been removed loosen front conical clamp connecting tail pipe to head pipe.



6. Remove muffer assembly from remaining hangers starting with the front hanger.

7. Slide rearward to allow the exhaust to clear the front crossmember and drop out. ****NOTE** do not damage or discard this clamp as it will be reused for the K&N Exhaust System.**

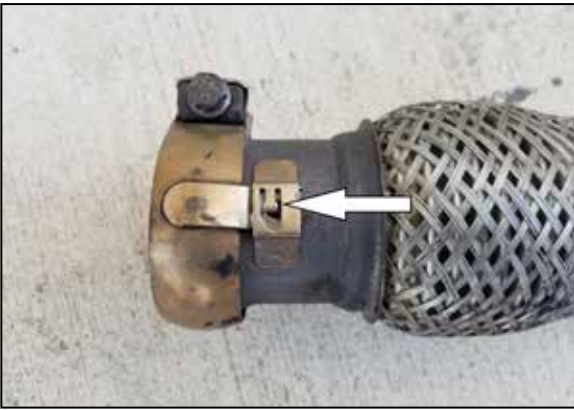

8. Once stock system is removed, remove the conical clamp by prying retaining tang upwards.

9. Install the stock conical clamp from the OEM system on the flared end of the mid pipe.



10. Slide mid pipe muffer assembly into position on the vehicle by first using the hangers on the muffer end. Once inserted, then slide assembly rearward allowing the mid pipe to seat against head pipe.



11. Slide band clamp on to the front of the tail pipe section. Then slide tail pipe section into muffler section. NOTE: Do not tighten the tail pipe connection at this time. Only enough to allow positioning of the tip to the body of the vehicle.



12. Check alignment and reposition as necessary. Once final position is satisfactory, tighten all hardware and band clamps from front to rear of vehicle. Clean exhaust tip of any finger prints or grease marks. **NOTE: All band clamps should be torqued to 40-45 ft-lbs.**

13. Double check to make sure everything is tight and properly positioned before lowering the vehicle to the ground.

ROAD TESTING:

1. Start the engine with the transmission in neutral or park, and the parking brake engaged. Listen for exhaust leaks or odd noises. For exhaust leaks secure flanges and/or connections. For odd noises, find cause and repair before proceeding. This kit will function identically to the factory system except for being louder.

2. Test drive the vehicle. Listen for odd noises or rattles and fix as necessary.

3. If road test is fine, you can now enjoy the added power and performance from your exhaust system.